



EUROHEATER
TACTICAL HEATING SYSTEMS

INDEX

ABOUT US	4
ADVANTAGES	5
EUROHEATER	7
Euroheater EvacCore	8
Euroheater 2D	10
Euroheater 4D	12
Euroheater 8D	14
CANHEAT	18
ACCESSORIES	20
MEDEVAC	23
RESCUE BAG	26
FLEXIBATT	30
Flexibatt 12V	32
Flexibatt PRO	34
Flexibatt PRO MIL	36
Flexibatt PRO MIL-SPEC	38
COMING IN SOON	40
Tactical Heatings Systems	41
ULTV System	42
Flexibatt MAXI	44

TACTICAL HEATING SYSTEM



TENTS



VEHICLES



BUNKERS &
TRENCHES



TEMPORARY & FIELD
MAINTENANCE
FACILITIES

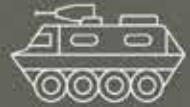

IFV AND APCS



COMMAND POST &
SIGNAL INSTALLATIONS



COMMUNICATIONS



MEDICAL &
FIRST AID POSTS



TANKS &
ARTILLERY



LOGISTICS &
REPAIRS

Shaping The Future Of Tactical Heating And Power Solutions

Euroheater AS was established in Norway in 2023 with a clear mission: to deliver the next generation of Tactical Heating Systems to defence forces, first responders, and professional users across Europe.

Through a strategic partnership with CanHeat Ltd — a leading Canadian manufacturer of portable heaters — we develop robust, safe, and efficient solutions that meet European standards and excel in field performance.

In addition to heating systems, Euroheater proudly introduces FLEXIBATT: a Norwegian-designed, high-performance battery built for demanding environments. Driven by innovation and reliability, Euroheater continues to expand its product portfolio to meet the evolving needs of the Nordic and European Defence sector.



HIGH QUALITY

Tactical Heating System designed and manufactured based on Canadian and Norwegian Arctic expertise. The heaters are third-party CE certified built with high-quality components to ensure a robust and reliable heat source.



DEVELOPED FOR DEMANDING CONDITIONS

Our air heater provides versatility with fuel options such as diesel, biodiesel, kerosene, JP8 and F34. The heaters deliver up to 72 hours of heat on one tank, due to their very energy efficient design.



SAFE AND EFFICIENT POWER SUPPLY

The unite requires either 12V (24V) or 110/230V power to operate the fuel pump and exhaust fan. The heaters are quiet, water-resistant, shockproof and portable. Easy to operate, starts and stops with the touch of one button.



ENHANCED OPERATIONAL SECURITY

A long air hose allows physical separation between the heat source and the heated area, reducing thermal signature and lowering the risk of target acquisition.





Image for illustrative purposes only

EUROHEATER

Tactical heating systems

Euroheater is a series of multi-fueled powered heating systems designed for maximum reliability. The heaters are designed for professional and tactical use, with a focus on stable performance, easy operation and minimal maintenance. The range has been thoroughly tested in demanding environments and maintains full output even in arctic temperatures and challenging terrain.



Battery and charger not included (sold separately).

Dimensions: 112 x 61 x 127 mm | Weight: 1.4 kg

BB-2590-Battery | Item No. BB-001

BB-2590-Charger | Item No. BB-005

EUROHEATER EvacCore™

TACTICAL AIR HEATER FOR FIELD OPERATIONS

The Euroheater EvacCore is a tactical air heater developed to deliver controlled and reliable active heating in the field, during evacuation, and under demanding operational conditions. The system was developed in response to direct needs from civilian rescue services and European special operations forces, with focus on low weight, rapid start-up, and high operational reliability.

EvacCore is guaranteed to be the lightest system in its class and is engineered as a complete all-in-one solution for efficient heat delivery without the need for external power supply.

Integrated Field Features

EvacCore is equipped with:

- Integrated 1.6-liter fuel tank
- Option for integrated MIL-BB2590 battery (optional equipment)
- Operating time of up to 25 hours (depending on configuration and load)

The system is designed to provide rapid heat deployment and stable performance in critical situations, including operations in extreme weather and temperature conditions. The unit can also operate in ventilation mode, supplying fresh outside air without activating the heating function.

Applications

EvacCore delivers adjustable heat output and airflow and can be used:

- As a standalone heating solution in the field
- As an integrated part of a system together with our the Rescue Bags

This makes the solution particularly suitable for:

- Stabilizing the microclimate inside a rescue bag
- Reducing heat loss during evacuation and transport
- Supporting patient management where hypothermia is a critical risk factor

EvacCore is a high-quality solution developed for professional users who require robustness, mobility, and operational functionality.



Patent pending



Image for illustrative purposes only

MODEL	2D EvacCore
Item No.	EH-005
Heat Capacity	1–2 kW (3.400–6.800 BTU/h)
Fuel Type	Diesel / Kerosene / F34 / JP8 / HVO
Fuel Consumption	0.10-0.24 l/h
Fuel Tank Capacity	1.6 liter
Ambient Air Temperature	+20 °C to –45 °C
Max. Altitude	5.400 meter
Power Consumption (Low–High)	10–29 W (0.8–2.42 A)

Air Flow, CFM (Low–High)	34–75 m ³ /h
Decibel (Max.)	60 dB
Dimensions (L x W x H)	432 x 330 x 241 mm
Weight	8.5 kg
Heater (Autoterm)	2D Diesel Air heater
Certification	CE
Rated Voltage	BB-2590 battery–MIL
Battery runtime (Low–High)*	20–8 h

*Depending of temperatur



EUROHEATER 2D

MULTIPURPOSE HEATING SYSTEM

The Euroheater 2D is developed for users who require a lighter and more compact heating solution. This is a reliable 2 kW air heater, built for smaller shelters, command posts, and mobile operations. The unit is housed in a rugged, water-repellent Nanuk case and operated through a sealed control panel, ensuring durability and simple operation in harsh environments.

The Euroheater 2D operates exclusively on 12 V power and must be connected to a compatible 12 V battery, such as a Flexibatt system.

The isolated combustion system provides clean, breathable air and safe heating performance inside the shelter. In addition to heating, the unit can operate in ventilation mode, supplying fresh outside air into the enclosed space without activating the heating function.

Patent pending

MODEL	2D
Item No.	EH-000
Heat Capacity (Low–High)	1–2 kW (3.400–6.800 BTU/h)
Fuel Type	Diesel / Kerosene / F34 / JP8 / HVO
Fuel Consumption	0.10-0.24 l/h
Fuel Tank Capacity	7.5 liter
Rated Voltage	12V DC
Ambient Air Temperature	+20 °C to –45 °C
Max. Altitude	5.400 meter
Power Consumption (Low–High)	10–29 W (0.8–2.42 A)
Air Flow, CFM (Low–High)	34–75 m³/h
Decibel (Max.)	60 dB
Dimensions (L x W x H)	550 x 295 x 410 mm
Weight	13 kg
Cables (Prysmian Group Carol)	-40 °C, UV-resistant, oil-resistant
Connectors	Neutrik
Heater (Autoterm)	2D Diesel Air heater
Certification	CE





NSN 4440-25-163-6858

EUROHEATER 4D

MILITARY TACTICAL HEATING SYSTEM

The Euroheater 4D is a 4 kW tactical heating system designed for reliable operation in demanding environments. It delivers stable heat for shelters, vehicles, and mobile operational setups.

The system is multi-fuel and multi-power, operating on different fuel types and supporting both 12 V and 230 V within the same integrated solution. Built with high-quality components and a rugged, field-proven construction, the Euroheater 4D is tested down to -45°C and up to 5,400 meters altitude, maintaining consistent performance in Arctic and high-altitude conditions.

The isolated combustion system provides clean, breathable air and a safe indoor environment. The unit can also operate in ventilation mode, supplying fresh outside air without activating the heating function. Designed for single-operator use, it requires minimal supervision and performs an automatic self-cleaning cycle to reduce maintenance and downtime.

The Euroheater 4D is currently the best-selling tactical heater in Europe.

Patent pending



Also available: The Euroheater 4D are available for search and rescue (Item no. EH-003) and civil defense operations (Item no. EH-001).

MODEL	4D
Item No.	EH-002
Heat Capacity (Low–High)	1–4 kW (3.400–13.600 BTU/h)
Fuel Type	Diesel / Kerosene / F34 / JP8 / HVO
Fuel Consumption	0.12–0.49 l/h
Fuel Tank Capacity	7.5 liter
Rated Voltage	12–17 V DC (*24 V DC); 100–240 V AC
Ambient Air Temperature	+20 °C to –45 °C
Max. Altitude	5.400 meter
Power Consumption (Start / Stopp)	100 W
(Low–High)	10–57 W
Air Flow, CFM (Low–High)	70–168 m³/h
Decibel (Max.)	60 dB
Dimensions (L x W x H)	650 x 325 x 430 mm
Weight	16.5 kg
Exhaust Emissions Maximum Value	C: 0.09% NOx: 80.9 ppm HC: 46.3 ppm
Cables (Prysmian Group Carol)	–40 °C, UV-resistant, oil-resistant
Connectors	Neutrik
Heater (Autoterm)	4D Diesel Air heater
NATO Stock Number (NSN)	4440-25-163-6858, Heater, Air Heater 4D
Certification	CE

*24V can be produced on order.





12 stk Euroheater 8D one euro pallet = 96 kW

EUROHEATER 8D

HIGH-IMPACT TACTICAL HEATING

The Euroheater 8D is a next-generation 8 kW tactical heating system developed for larger shelters, tents, and operational spaces. Despite its high output, the system maintains full multi-power flexibility, operating on both 12 V and 230 V to ensure adaptable use across different platforms and power sources. It also supports multiple fuel types, providing operational versatility in the field.

Weighing only 29.5 kg, the 8D is designed as a lightweight system for simplified logistics. Integrated wheels allow easy transport, and the unit offers very low fuel consumption compared to other systems in its class.

The system is compatible with a standard 20 L NATO jerry can, providing up to 20 hours of operation at full output and up to 7 days on the lowest setting. This makes it one of the most fuel-efficient tactical heating solutions available on the market.

Built for Demanding Field Operations

Built into a heavy-duty, shock-resistant, and water-resistant case, the Euroheater 8D is engineered for demanding environments. It delivers twice the heating capacity of the 4D model while maintaining efficient fuel usage and low noise levels.

Designed for rapid deployment, the system can be set up by a single operator in under five minutes. The isolated combustion process ensures that only clean, breathable air enters the heated space, providing a safe and stable indoor climate even in extreme sub-zero conditions. In addition to heating, the unit can operate in ventilation mode, supplying fresh outside air without activating the heating function.



Designed in Norway

Patent pending





Image for illustrative purposes only

MODEL	8D
Item No.	EH-004
Heat Capacity (Low–High)	1–8 kW (3.200–27.200 BTU/h)
Fuel Type	Diesel / Kerosene / F34 / JP8 / HVO
Fuel Consumption (Low–High)	0.12–0.98 l/h
Fuel Tank Capacity *	20 liter – standard NATO cans
Nominal Voltage (DC, external battery)	12.5 V
Nominal Voltage (AC)	220 V / 50 Hz – 120 V / 60 Hz
Ambient Air Temperature	+20 °C to –45 °C

*The unit uses an external 20-litre jerry can as its fuel tank.

Max. Altitude	5.400 meter
Power Consumption (Start / Stopp) (Low–High)	200 W 10–114 W
Air Flow (Low–High)	70–240 m³/h
Decibel (Max.)	60 dB
Dimensions (L x W x H)	635 x 635 x 345 mm
Weight	29.5 kg
Exhaust Emissions Maximum Value	C: 0.09% NOx: 80.9 ppm HC: 46.3 ppm
Certification	CE



HIGHLY FLEXIBLE DEPLOYMENT

Designed for both fixed and mobile use.
Compatible with vehicles such as IFVs,
APCs, tanks, and vessels, using dedicated
mounts or straps for quick integration



FIELD-TESTED RELIABILITY

Tested at -45 °C and 5,400 m altitude over 8 continuous weeks. Euroheater delivers consistent heat output in extreme conditions. Proven to operate reliably in both Arctic and high-altitude environments.



LOW MAINTENANCE

Simple, single-operator use reduces personnel requirements. The system is self-cleaning when used correctly, minimizing downtime and maintenance requirements.



CLEAN OPERATION

Euroheater delivers heat without open flames, low CO emission and without combustible fuel inside tent or shelter. This ensures safe and more environmentally friendly heating.



FUEL EFFICIENCY

Euroheater uses up to 2/3 less fuel than conventional systems and supports multiple types of fuel. Significantly reducing resupply needs and easing logistics in the field.



DRY, HOT AIR OUTPUT

Speeds up drying of wet gear and clothing. Reduces humidity and corrosion, and improves airflow in shelters and vehicles.



LOW ACOUSTIC SIGNATURE

Operating at just 60 dB on full power (measured at a distance of 1 m), the system ensures minimal acoustic footprint, significantly reducing the risk of detection in tactical environments. The system meets NATO standards for acoustic signature.



CANHEAT MULTI-POWER SYSTEM

CanHeat is a compact, dual-box heating system designed for silent, off-grid operation. It runs on NATO-standard BB-2590 batteries and supports external AC and DC power inputs.

With an integrated control system and quick-connect setup, CanHeat offers extended runtime and full deployment in under five minutes.

- **Compact CPB Unit**
- **Docks 3xBB-2590**
- **MIL-Spec Connectors**
- **LED Control Panel**

Patent pending



Docks 3 x BB-2590



LED control panel



MIL-spec connectors

MODEL	CANHEAT MULTI-POWER
Item No.	EH-CAN-01
Heat Capacity (Low-High)	1-4 kW (3.400-13.600 BTU/h)
Fuel Type	Diesel, Kerosene, JP-8
Fuel Consumption	0.12-0.5 l/h
Rated Voltage	12-17 V DC; 100-240 V AC
Power Consumption (Low-High)	10-57 W
Air Flow Rate (Low-High)	70-120 m ³ /h
Dimensions	
Heater	622 x 457 x 330 mm
Control Power Box (CPB)	432 x 330 x 240 mm
Weight	
Heater	15 kg
Control Power Box (CPB)	6 kg

CANHEAT MULTI-POWER SYSTEM INCLUDES

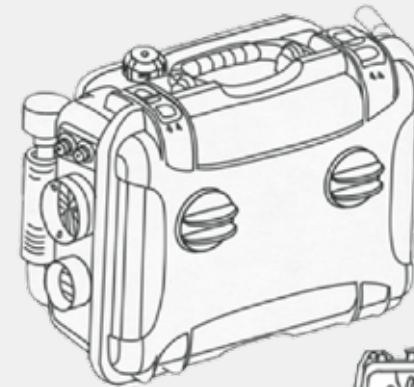

Heater Core

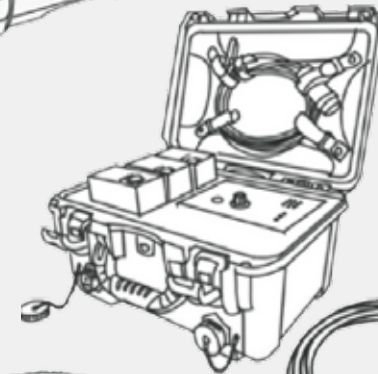

CPB Unit



Air Duct

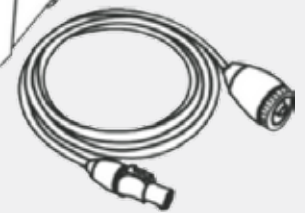

Cabling



VEHICLE MOUNT

A durable transport stand engineered for secure vehicle integration and rapid field deployment. It allows quick assembly and operation with the heater directly from the stand.
Item No.: EH-10108



PROTECTIVE COVER

Durable cover engineered for long-term storage of Euroheater units. Shields critical components from dust, moisture, and environmental wear.
Item No.: EH-10100



PROTECTIVE BAG L

Rugged transport bag designed to safeguard Euroheater units during handling and field transport. Provides protection against impact, abrasion, and weather exposure.
Item No.: EH-10102



PROTECTIVE BAG MEDIUM

Protects the Euroheater heating hose during transportation and storage. Keeps the hose organized and shielded from dirt, moisture, and damage. Designed for easy handling and helps extend the lifespan of your hose.
Item No.: EH-10104



NANUK CASE

Nanuk Case Model 940, olive color. Shockproof and waterproof, compliant with MIL specifications.
Item No.: EH-100



HEAVY LOAD CARRIER

A rugged, mission-ready backpack engineered to carry bulky equipment. It has an ergonomic and modular design with an adjustable load compartment for versatile storage and balanced weight distribution.
Item No.: EH-10110



ACCESSORY BAG

Protects and organizes small components during transportation and storage. The compact and easy-to-carry bag ensures that accessory and spare parts are protected and ready for use.
Item No.: EH-10106



AIR HOSE

Flexible and reinforced air hose that withstands temperatures up to 140 °C. Standard length is 3.3 meter. Custom lengths available on request. Transport case is available as an accessory.
Item No.: EH-007 (60 mm)
Item No.: EH-006 (76 mm)



CO ALARM

Engineered for precision and durability, the Euroheater CO Alarm is built on the latest electrochemical sensor technology with smart, processor-controlled temperature compensation. Using premium components, the unit delivers long service life without recalibration or modification. The sensor ensures ultra-low power consumption, one standard AA battery provides up to five years of continuous operation.

Encased in a rugged, impact-resistant housing, the alarm is built to withstand heavy use and harsh field environments. It activates automatically when CO concentrations exceed 95 ppm.

Developed and manufactured in Norway.
Weight: 55 g | Dimensions (LxWxH): 60 x 60 x 27 mm

Item No.: EH-10112



MODULAR ACCESSORIES FOR ANY MISSION

Supplied with mission-specific accessories, including transport covers, compatible vehicles mounts, and backpack carrier systems, for streamlined transport, storage, and rapid deployment.



Image for illustrative purposes only

SOLUTIONS FOR COLD WEATHER OPERATIONS – PREVENTING HYPOTHERMIA

In tactical and high-risk operations, exposure to cold, wind, and moisture gradually reduces control, precision, and decision-making ability. Heat loss starts immediately in demanding environments, long before critical limits are reached.

Euroheater develops solutions for evacuation, transport, and operational standby that help maintain thermal stability in cold and exposed conditions. By limiting heat loss and shielding against wind and moisture, our systems support performance, resilience, and safe operations when conditions are at their most challenging.



MEDEVAC HEATED STRETCHER

Euroheater has developed a heated Medevac Stretcher compatible with all standard NATO stretchers as well as civilian rescue systems. Designed to reduce the risk of hypothermia during evacuation and transport, it provides active thermal support to help improve patient survival in critical conditions.

The stretcher is manufactured from highly durable, waterproof PVC and supports loads up to 200 kg. The electronic system is based on 12 V low-voltage technology and features integrated sensors that individually regulate multiple heating zones, maintaining a stable temperature between 36–38 °C — even in cold environments.

The power is supplied by a MIL-standard BB-2590 battery (290 Wh), delivering up to 3 hours of continuous operation per battery. The integrated battery pocket accommodates up to two batteries for extended runtime. Civilian battery solutions can also be connected using a dedicated adapter, ensuring flexibility across military and civilian operations.



Made in Norway

Patent pending



Battery and charger not included (sold separately).

Dimensions: 112 x 61 x 127 mm | Weight: 1.4 kg

BB-2590-Battery | Item No. BB-001

BB-2590-Charger | Item No. BB-005

PREVENT HYPOTHERMIA – SAVE LIVES

MODEL	MEDEVAC
Item No.	EH-10115
Capacity (Max.)	180 W
Operating voltage (low-voltage)	12 V DC
Power*	MIL-standard BB-2590 battery
Battery capacity	Up to 3 hours per battery
Temperature range	36–38 °C
Material	Waterproof, heavy-duty PVC
Maximum load capacity	200 kg
Dimensions	1900 x 600 mm
Weight	1.9 kg

**Civilian battery systems can also be used with a dedicated adapter.*





Item No. EH-10113

RESCUE BAG SYSTEM

Developed in Norway, the Rescue Bag System is a unique solution designed to protect operational capability during cold exposure. It is built to maintain function in cold, wet, and demanding environments.

At the core is the Rescue Bag, a robust thermal bag that creates an effective barrier against wind, moisture, and cold. It reduces heat loss and can be used independently as passive protection during waiting, immobilization, and transport.

External warm-air module (heater)

A self-contained external air heater supplying tempered air to the internal volume of the bag. Heat is applied to the surrounding environment, Without direct influence on the body.

The system has:

- no sensors on the person
- no temperature regulation targeting the individual
- no therapeutic function

TECHNICAL KEY POINTS

- Dyneema®-based construction
- 100% hydrophobic
- Approved for up to 100 use cycles
- 360° patient access



Made in Norway

DYNEEMA®

The bag is constructed from a Dyneema®-based composite that offers an exceptional strength-to-weight ratio. The material is up to 15 times stronger than steel, while the total bag weight is only 1390 grams.

HYDROPHOBIC MATERIAL

The material is 100% hydrophobic, meaning it does not absorb water, blood, or bodily fluids. Liquids remain on the surface rather than penetrating the fabric.

Approved for up to a 100 use cycles.

HOW IT WORKS

An individual is placed inside The Rescue Bag, which immediately establishes a barrier against cold, wind, and moisture. When required, tempered air can be introduced to maintain a stable microclimate over time. The result is reduced energy loss, preserved functional capacity, and reduced demand on medical resources.





ACTIV HEAT FOR SAVING LIVES (Optional accessory)

The system can be expanded with an external warm-air module when additional stabilization is required during prolonged exposure. The heater is an optional accessory.



MODEL	RESCUE BAG Adult
Item No.	EH-10113
Insulation	PrimaLoft® Gold PURE™, 170gsm
Insulation CLO-value	4.0 - Equivalent to advanced alpine sleeping bags
Outer/inner material	Bio-Based Dyneema® Composite Fabric
Waterproof rating	> 20,000 mmH ₂ O
Vapor barrier	Near-zero permeability (< 1 g/m ² /24h)
Sanitation	Cleanable with standard detergents and UVC light
Washing	Machine washable up to 60°C
Carry system	10 integrated lifting straps
Access features	4 puller 360° zipper; 3 puller chest zipper
Dimensions (L x W)	220 x 100 cm
Compressed size (L x W x H)	38 x 18 x 16 cm
Weight (incl. compression bag)	1390 grams



FLEXIBATT

Reliable Power – Anywhere

The Flexibatt series is a new generation of rugged, Norwegian-designed power systems built for military, emergency, and field applications. Developed for arctic conditions, every unit is engineered to operate reliably in extreme temperatures and withstand shock, dust, and water exposure. Every unit is designed for mobility and ease of use. They are simple to transport, store, and deploy. Every detail — from the compact form factor to the intuitive interface, is created to make reliable power accessible wherever it's needed.



Image for illustrative purposes only



FLEXIBATT

Flexibatt is a core battery platform developed and manufactured in Norway for demanding use in Arctic conditions. It serves as the foundation for multiple configurations tailored to operational requirements in both civilian and military environments.

Designed to power Euroheater air heaters as well as sensors, drones, communication systems, and other mission-critical equipment, Flexibatt delivers reliable energy across a wide range of field applications. Its modular design allows flexible integration and scalable solutions for diverse operational needs.

Built with advanced technology and high energy-density cells, Flexibatt sets a strong standard for cold-weather battery performance. Norwegian-produced Flexibatt systems are currently in operational use across several European countries, including Ukraine.

With a capacity of 2.5 kWh and a compact weight of only 12.1 kg, Flexibatt provides stable and continuous power for extended field operations. It can power the Euroheater 4D for up to three days on its lowest setting and maintains full performance in temperatures down to -20°C .

Integrated DC/DC Converter

Flexibatt includes an integrated DC/DC converter housed in cold-resistant aluminum. The converter enables power delivery through multiple output options and supports both 12 V and 24 V equipment. It features USB-B and USB-C outputs, as well as a standard Neutrik connector designed to power all Euroheater air heaters.

This configuration makes Flexibatt ideal for rapid charging of drones, night optics, sensors, communication systems, and other high-demand equipment operating in harsh Arctic conditions.

The unit is fully waterproof (IP66 rated), shock-resistant, and engineered to deliver reliable energy whenever and wherever it is required — even in the most demanding environments.



Euroheaters



Drones



Night Optics



Communication



Laptops



Made in Norway

Patent pending

MODEL	FLEXIBATT
Item No.	NOR0001
Voltage	48V nom.
Capacity	2.5 kWh (2.4kWh nom.)
Continuous discharge	3 kW (Peak 4 kW)
Voltage range	33.8V - 54.6V
Communication	RS485 / CAN
Parallel connection	Supported with Paralell module
Recommended charging status (during storage)	40 - 60%
IP Rating	IP66
Ambient operating temperature	
Discharge	-20 to +55°C
Charging	+5 to +40°C
Storage	-20 to +55°C
Weight	12.1 kg
Dimensions (L x W x H)	480 x 278 x 85 mm

MODEL	FLEXIBATT IVR-12V/24V
Item No.	NOR0005
Voltage (Input)	48V
Voltage (Output)	12.5V
Connectivity	4x USB-C (PD Supported) / 65W 2x USB-A (QC) 1x Neutrik n14mpxx Speakon
Material housing	Aluminium
IP-Rating	IP55
Ambient operating temperature	-20 to +55°C
Weight	0.35 kg (+ 12.1 kg battery)
Dimensions (L x W x H)	225 x 67 x 80 mm





FLEXIBATT PRO

PROFESSIONAL MODULAR 48V POWER SYSTEM

Flexibatt PRO is our standard model — a powerful and modular 48 V battery system built for professional users and demanding off-grid operations. Delivering 2.5 kWh of reliable energy, it provides 230 V output with 2500 W continuous power and up to 3500 W peak capacity, giving you the performance needed to run tools, equipment, and critical systems without interruption.

The PRO version is equipped with two 230 V Schuko outlets, dual 100 W USB-C PD3.1 ports, two USB-B ports, and a dedicated Neutrik connector for seamless operation of all Euroheater air heaters. This versatile output configuration ensures compatibility with a wide range of professional equipment.

An integrated 10 A charger (480 W) combined with solar input up to 900 W enables flexible charging from both grid power and renewable energy sources. Whether connected to mains electricity or solar panels, Flexibatt PRO keeps your operation running.

Engineered for cold and demanding environments, Flexibatt PRO delivers stable performance when it matters most. It is an ideal solution for powering tools and electronic equipment at remote cabins, construction sites, emergency operations, or in the field.

Built into a rugged IP54-rated enclosure, the system is designed for durability and long service life. The modular battery design allows fast battery replacement, ensuring continuous operation in situations where downtime is not an option.



Patent pending



MODEL	FLEXIBATT PRO
Item No.	NOR0004
Battery Voltage	48 V nom.
Capacity	2.5 kWh (2.4kWh nom.)
Output	
230V	2500W
12V	240W (max)
USB	2x100 (max)
Built-in Charger	10A (480 W)
Ambient Operating Temperature	
Discharge	-20 to +55 °C
Charging	+5 to +40 °C
Storage	-20 to +55 °C
Weight	26.5 kg
Dimensions (W x L x H)	557 x 429 x 216 mm
IP rating	IP54

MODEL	SOLAR PANEL
Item No.	NOR0031
Solar Input	900 W
USB Ports (1 x USB-C, 1 x USB-A)	65 W





FLEXIBATT PRO MIL

DUAL-VOLTAGE FIELD POWER SYSTEM

Flexibatt PRO MIL is engineered for field operations requiring both AC and dedicated 24V power. Based on the PRO platform, it delivers 2.5 kWh capacity and a 2500W 230V AC output, while adding a robust 24V outlet (480W max) via Amphenol connector for mission-critical equipment.

In addition to the 24V output, the system provides a 12V outlet (240W max) and dual 100W USB-C PD3.1 ports for communications and portable electronics. Integrated 10A charging (480W) and solar input up to 900W ensure operational flexibility in remote environments.

Designed for reliability, mobility, and tactical versatility, PRO MIL supports both standard AC equipment and specialized 24V field systems in one compact unit.



Patent pending





Image for illustrative purposes only

MODEL	FLEXIBATT PRO MIL
Item No.	NOR0002
Battery Voltage	48 V nom.
Capacity	2.5 kWh (2.4kWh nom.)
Output	
230V	2500W
12V	240W (max)
USB	2x100 (max)
Built-in Charger	10A (480 W)

Ambient Operating Temperature	
Discharge	-20 to +55 °C
Charging	+5 to +40 °C
Storage	-20 to +55 °C
Weight	26.5 kg
Dimensions (W x L x H)	557 x 429 x 216 mm
IP rating	IP54
Solar Input	900 W



FLEXIBATT PRO MIL-SPEC

HIGH-PERFORMANCE DC TACTICAL POWER UNIT

Flexibatt PRO MIL SPEC is optimized for advanced DC-based systems. Delivering 2.5 kWh of energy, it replaces the AC outlet with dedicated high-power DC outputs: 48V (2200W max) and 24V (480W max).

The unit also features three 100W USB-C PD3.1 ports (300W total), enabling simultaneous charging of modern mission electronics. With integrated 10A charging (480W max) and solar input up to 900W, the system ensures continuous field readiness.

By eliminating the AC inverter stage, MIL SPEC provides improved efficiency and seamless integration with 48V and 24V platforms.



Made in Norway

Patent pending



Euroheaters



Drones



Night Optics



Communication



Laptops

MODEL	FLEXIBATT PRO MIL-SPEC
Item No.	NOR0003
Battery Voltage	48 V nom.
Capacity	2.5 kWh (2.4kWh nom.)
Output	
230V	2200W
12V	480W (max)
USB	3x100 (max)
Built-in Charger	10A (480 W)
Max. Solar Input	900W
Ambient Operating Temperature	
Discharge	-20 to +55 °C
Charging	+5 to +40 °C
Storage	-20 to +55 °C
Weight	26.5 kg
Dimensions (W x L x H)	557 x 429 x 216 mm
IP rating	IP54



SOLAR PANEL

Lightweight and foldable solar panel designed for charging Flexibatt PRO series. Delivers up to 300 W input for efficient recharging in off-grid environments. Built with durable, weather-resistant materials to ensure reliable performance in demanding conditions.

Dimensjons (W x L x H): 39 x 23 x 7,5 cm
Weight: 7 kg

Item No.: NOR0031

A portable heater unit, labeled "EUROHEATER", is connected to a tent via a corrugated vent pipe. The setup is in a snowy environment. The heater is a dark, rectangular unit with a control panel and a vent pipe that runs through the tent's fabric. The tent is a light-colored, possibly white or tan, and is pitched in a snowy area. The heater has a label that reads "EUROHEATER" and "ELECTRIC".

**INNOVATION IN PROGRESS
AVAILABLE IN 2026**

EUROHEATER UNIVERSE

TACTICAL SYSTEM INTEGRATIONS

We are developing a system for tactical ULTV/UTV-ATV platforms and marine RIB craft.

Euroheater is a portable heating system engineered for military tactical vehicles. The unit connects to a standardized docking station that allows for quick connection and disconnection without the need for tools.

The system utilizes the air-heating modules through a universal frame system to deliver heat to soldiers on the move on vehicles in arctic environments, which provides:

- Flexibility: A single unit can be used across multiple platforms.
- Speed: Installation and movement between vehicles take only seconds.
- Operational effectiveness: A stable heat supply improves comfort, endurance and combat capability.
- Safety: Reduced risk of cold injury and hypothermia in the field.



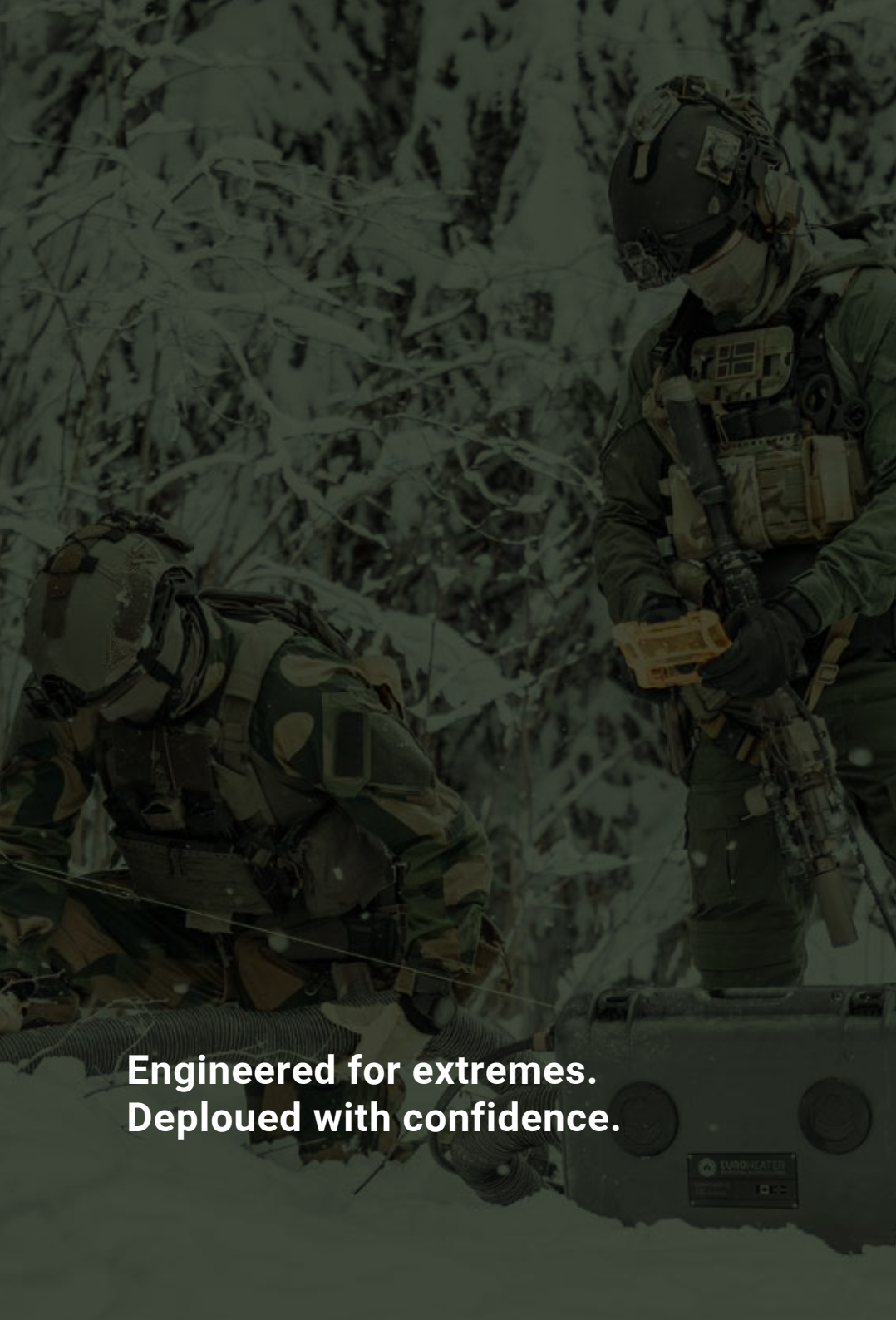

**Engineered for extremes.
Deployed with confidence.**



EUROHEATER ULTV SYSTEM

A vehicle-mounted heating system built for Ultra Light Tactical Vehicles such as Polaris DAGOR, Polaris MRZR, and GM Defense ISV. Compact and integrated, it delivers cab-safe heating, dashboard control, and rapid ducted airflow, with the flexibility to quick-disconnect for shelter use when required.

- Integrated vehicle unit with dashboard controls and quick-connect wiring loom.
- Rugged mounting system designed for tactical and off-road vehicles.
- Vibration-tested, dust-protected, and field-ready,
- Compatible with onboard 12 V DC and external 100–240 V AC power inputs

Patent pending

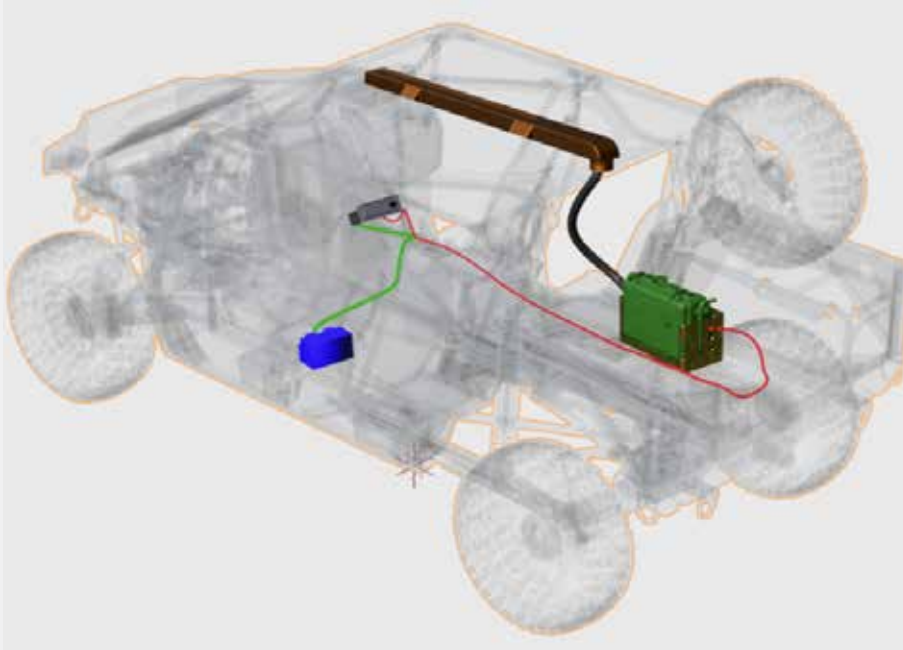

MODEL	ULTV SYSTEM
Heat Capacity (Low-High)	1-4 kW (3.400-3.600 BTU/h)
Fuel Type	Diesel, Kerosene, JP-8
Fuel Consumption	0.12-0.5 l/h
Rated Voltage	12-17 V DC; 100-240 V AC
Power Consumption (Low-High)	10-57 W
Air Flow Rate (Low-High)	17-120 m ³ /h
Dimensions	622 x 457 x 330 mm
Weight	17 kg

ULTV SYSTEM INCLUDES

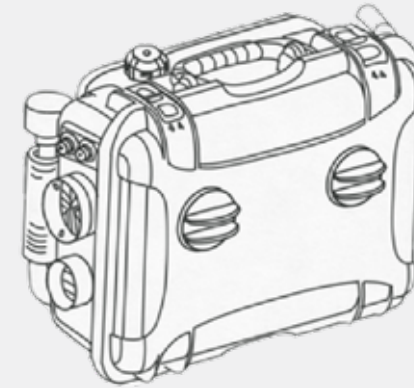

Heater Core

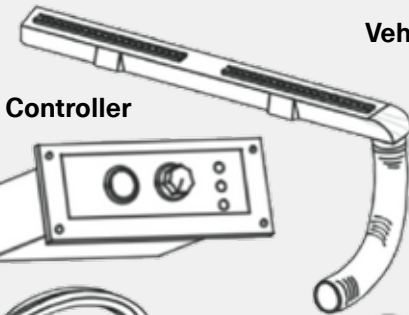

Vehicle Air Duct

Dashboard Controller



Cables

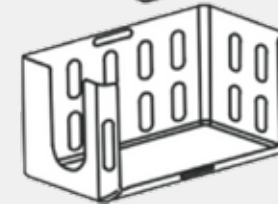

Mounting System



FLEXIBATT MAXI

UPS AND POWER SYSTEM

Flexibatt MAXI is a high-capacity UPS and power storage system. The system combines a master unit with modular 5 kWh UPS power units, scalable up to 50 kWh depending on operational needs.

Lightweight, portable, and built for rapid deployment, Flexibatt MAXI delivers continuous, reliable power for field hospitals, command posts, and other energy-intensive operations in harsh or remote environments.



Patent pending



MODEL	FLEXIBATT MAXI
Type	Modular UPS and power system
Capacity	Scalable from 5 to 50 kWh
Output	230 V and 400 V, 12V USB-C/ USB-A
Operating Temperature	-20 °C to +60 °C
Charging Option	Generator, direct AC or solar panel
Availability	Market launch 2026



EUROHEATER

TACTICAL HEATING SYSTEMS

EUROHEATER AS
Masteveien 8, 1481 Hagan
Norway
www.euroheater.no
post@euroheater.no

